



X-one



X-oneTCi

SOFT VERS. 1.04 & SC 1.03

TECHNICAL DOCUMENTS

CONTI - Edition 05/2014

SACOME, CONFIDENTIAL Document, it is forbidden to duplicate or communicate this document without previous authorization.

1	TECHNICAL DOCUMENTS	3
2	DIMENSIONS	3
3	CAUTION DURING THE USE	4
4	INSTALLATION	5
5	OPERATION	7
6	HOW TO USE THE MACHINE	8
7	PROGRAMMING METHODOLOGY	10
8	BAR MENU PROGRAMMING PARAMETERS:	14
9	TECHNICAL MENU PROGRAMMING:	18
10	ALARM MESSAGES AND SOLUTIONS:	24
11	SUMMARY OF PROCEDURE FOR RESETTING THE COUNTERS	26
12	TROUBLESHOOTING FACILITATORS	27
13	METHOD OF ADJUSTING COFFEE TEMPERATURE ON X-ONE MODEL	28
14	METHOD OF ADJUSTING COFFEE TEMPERATURE ON X-ONE TCI MODELS	29
15	HOW TO MAKE THE PERFECT COFFEE	31
16	MAINTENANCE OF MACHINES	33
17	ELECTRONIC DIAGRAM STANDARD VERSION	36
18	HYDRAULIC SCHEMA	42
19	OPTION AVAILABLE	43

1 TECHNICAL DOCUMENTS

MACHINE TYPE	HEATING POWER (Watt)	INSTALLED POWER (Watt)	POWER USED (Amps).	
			230V	400V
2G Esp or TC monophase	3500	3800	17	--
3G Esp or TC triphase	6000	6300	--	10A / Ph
2G TCI Esp or TC triphase	4200	4500	--	7A / Ph
3G TCI Esp or TC triphase	6000	6300	--	10A / Ph

On option:

2G Esp or TC triphase	4200	4500	--	7A / Ph
3G Esp or TC monophase	4700	4900	22	--
2G TCI Esp or TC monophase	3500	3800	17	--
3G TCI Esp or TC monophase	4700	4900	22	--

CAPACITY OF BOILER IN LITERS		
	2G	3G
TOTAL	13	20
VOLUME OF HOT WATER	10	15
VOLUME OF STEAM	3	5

	WEIGHT (Kg)	WEIGHT WHEN WORKING (Kg)
2G	58	71
3G	72	91

2 DIMENSIONS

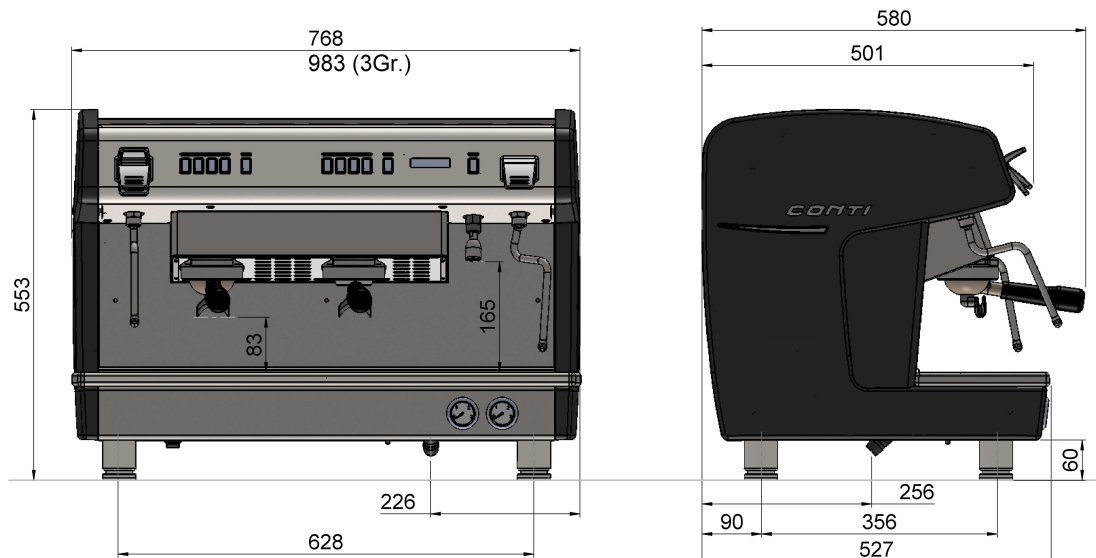

3 CAUTION DURING THE USE

3.1 AMBIENT CONDITIONS

- The ambient temperature around the machine had to be between 5°C et 32°C.
- The ambient humidity must not exceed 70 %
- The machine must be placed such as the cup warmer is located more than 1.5 meters from the ground.

3.2 DURING INSTALLATION

- The installation (electrical connections, water supply and drainage) must be carried out by a qualified technician approved by CONTI.
- The machine must be connected to a device conforming to the standards of the country where the machine is installed. Potential costs of equipment compliance are the only responsibility of the customer.
- For any technical intervention, the machines must always have the power disconnected from the mains.
- An effective earth connected to the terminal provided for this purpose on the device is mandatory
- A screw located under the bottom base machine, allow if necessary, to connect several machine on an equipotential way.
- Devices for disconnection from the main supply, having a contact separation of at least 3mm in all poles, must be provided in the fixed wiring in accordance with the installation rules.



3.3 DURING THE USE

- When the machine is not operating, the water cut-off valve has to be closed and the electrical power supply cut.
- When the machine is not supervised it must be disconnected from the power and water supply.
- Never disconnect the earthing when the machine is connected to the power supply.
- Machines must always be disconnected from the main power, in case of technical interventions.

3.4 RULES RELATING TO THE ENVIRONMENT

- This device has been designed according to the European Directive No. 2002/95/EC. This refers to the restriction of certain hazardous substances in electrical and electronic equipment (ROHS)
- This device has been designed in compliance with the European Directive No. 2002/96/EC concerning waste electrical equipment (WEEE).
- This picture informs you that this device should not be discarded with household waste.
- At end of life, this product must be returned to a collection point or returned to an authorized dealer. By doing so, you will help to protect the environment and human health.



4 INSTALLATION

4.1 IN CASE OF A STANDBY OF THE MACHINE (STANDBY = 2 MONTHS):

- The first thing to do is to test your machine in a lab.
- If the machine stop running for a long time, you could have scale in some places.
- More precisely in small area like the spray nozzle.

4.2 PROTECTIONS

- It is necessary to place before the machine:
 - A water shutoff valve.
 - An electrical protection standard, suitable for voltage and power consumption.

4.3 WATER SUPPLY

- Recommended operating pressure from 1.5 MPa to 6 MPa
- Water connection pin 3/8"
- The water supply pipes must resist to 145 Psi / 10 MPa

4.4 DRAIN

- Sans pression.
- **Spigot at the outlet of the machine and a pipe is supplied with the machine**
- Ensure a connection that causes no risk of fluid return, and ensure good drainage:
 - The drain pipe must be located lower than the machine.
 - Do not create a bend in the exhaust tube.

4.5 SUPPLYING VOLTAGE

- To be specify when ordering : 230V – 50/60Hz Monofase
- Or : 400V – 50/60Hz Trifase

4.6 **WATER SOFTENERS**

- When the mains water has a high hardness ($>10^{\circ}\text{TH}$ ou $>4^{\circ}\text{KH}$), it is recommended:
 - To use a water treatment
 - To regenerate regularly the filters.

- What is the **total Hardness of the water** ?
 - This is the amount of calcium and magnesium ions in the water.
 - These ions are partly responsible for limestone formation.
 - It is measured with the test strip provided with the machine.
 - The unit of measurement is the $^{\circ}$ French ($^{\circ}\text{TH}$) or the $^{\circ}$ German ($^{\circ}\text{dH}$).

- What is the **Karbonat Hardness of the water** ?
 - This is the amount of Carbonate Calcium ions and Carbonate Magnesium ions in the water.
 - These ions are completely responsible for limestone formation.
 - It is measured with chemical dropper testers.
 - The unit of measurement is $^{\circ}$ Carbonate ($^{\circ}\text{KH}$)

There are 2 types of water treatments:

- Salt water softeners
 - They treat the total water hardness ($^{\circ}\text{TH}$)
 - By an exchange of sodium ions with calcium and magnesium ions.
 - They require periodic regeneration of the resins by the user.
 - To use when the water hardness is $> 10^{\circ}\text{TH}$ ou $> 5^{\circ}\text{GH}$

- Resins filters :
 - They treat the Carbonat hardness water ($^{\circ}\text{KH}$)
 - By fixing carbonate ions on the resins.
 - Often fitted with microfiltration and carbon filtration.
 - To use when the Carbonat Hardness is $> 6^{\circ}\text{KH}$
 - Highly recommended by the manufacturer :
 - The machines are equipped with suitable protection in accordance with flowrate and the water encountered.
 - The changing cartridges is carried out by the technical service, at intervals to be determined

5 OPERATION

5.1 RECOMMENDATIONS

- Open the general water tap, if it is closed, then open the water shutoff valve dedicated to the machine.
- Do not put the supplying voltage at this moment.
- Verify the presence of water, by reading the pressure of the mains water inlet on the M2 manometer pump.

5.2 INITIAL FILLING

- Ensure that steam taps operating levers 'V' are open (up).
- Put the ON/OFF switch 'C' to position 1 (power on).
- Bar led under the key board turn to on.
- The boiler fills automatically, without heating.
- The machine start to heat automatically, only when the level probe is reached by the water
- A scrolling LED on keypads can inform the user about the status (display shows: "boiler heating")
- Close the steam tap "V" and wait.
- When the scrolling leds stops : **The machine is ready to operate** (display shows: « Hour + T° + X-ONE »)

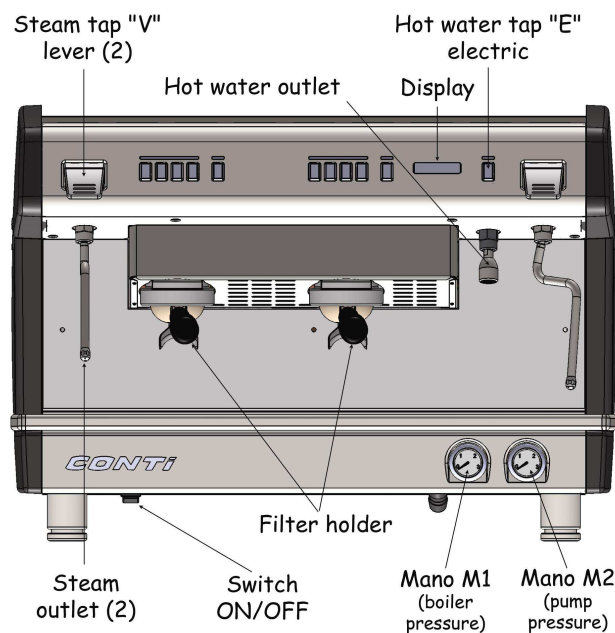

5.3 FURTHER FILLINGS

- Further fillings will run automatically, according to the hot water needs.
- The water level in the boiler is controlled by the electronics, by the means of a level probe.

6 HOW TO USE THE MACHINE

6.1 OPERATING ELEMENTS

➤ **STEAM FUNCTION**

Two steam taps levers « V » are provided to allow:

- The heating of liquids by spraying steam.
- The milk foam production to create Cappuccino or Macchiato.

The liquid to be heated should preferably be placed in a deep container.

The tip of the steam wand outlet must be immersed in the liquid, without touching the bottom of the container.

The steam may also be used to sterilise and warm glasses.

After each use and absolutely **after heating milk**, always clean the stainless steel steam nozzle and the outlet nozzles with a damp cloth, removing all traces present.

A rinsing of the steam lance inner holes is to be done by a short pulse on the lever downwards to release a jet of steam.

➤ **HOT WATER FUNCTION**

Electric tap 'E' is provided for preparing tea, grog, etc.

Be careful, not to be burnt by the pressure water spray.

For that, the valve is coupled to a cold water mixing for adjusting the T ° water for teas and avoid spitting hot water.

➤ **FILTERS**

The machine is equipped with two types of filters: 1 cup and 2 cups.

Each filter is operating with its own holder-filter to produce respectively 1 cup or 2 cups of coffee.

Filters need to be unclogged and clean, so they need to be cleaned almost once a day with hot water, by being removed from the holder filters.

Take care to remove all residual traces of coffee and ensure proper cleanliness of perforations in the bottom of the filter.

➤ **FILTER-HOLDER**

Never remove the filter-holder during operation of the group. The shutdown is controllable with coffee spouts: they no longer have to eject liquid.

Be careful to always keep the filter-holder engaged in the group, emptied of coffee cake, to keep them warm.

In case of an extended stopping period, remove the filter-holder from the group, taking care to eject the used grounds remain in the filter-holder.

Tighten the filter-holder until to be in contact with the seal, exceeding a little bit. The sealing is guaranteed.

Do not unnecessarily try to crush the seal by tightening the filter at the maximum of your possibilities. It may damage the seal or to age prematurely.

To empty the coffee filters used, turn the filter holder upside-down and lightly tap it on the edge of a wooden box. Never strike it against metal or other hard objects.

➤ **MANOMETER M1 : BOILER PRESSURE**

The boiler pressure is adjusted in factory between 0,8 MPa (12 PSI) and 1 MPa (15 PSI). This value varies slightly around its nominal temperature, due to the PID system which controls the heating and limit the current consumption to its minimum.

Factory settings:

1. X-One = 1 MPa with setting range from 0.8 MPa to 1 MPa.
2. X-One TCi = 1.2 MPa with setting range from 1.0 MPa to 1.4 MPa .

NOTE: An over-heating thermostat cut the power on the general relay, in case of an abnormal high temperature. The machine is not anymore supplied.

➤ **MANOMETER M2 : PUMP PRESSURE**

The pump pressure is adjusted at 9 MPa in the factory. Value which allows the best extraction of coffee flavors. A bypass system evacuates over-pressure.

NOTE: Simultaneous operation of all the groups can impact a little bit the pressure level.

Visualization of the presence of water network is done by consulting the gauge

6.2 HOW TO USE THE PROGRAMMED DOSES

- Simply select one of the buttons available on each keypad to obtain the doses or the programmed drinks.
- The selected dose is shown by a blinking led on the keypad.
- The flow can be stopped by repressing:
 - The same button or
 - The STOP button (which is also the programming and continuous flow button).

7 PROGRAMMING METHODOLOGY

On the 1° group, 4 buttons are used for programming as follows:

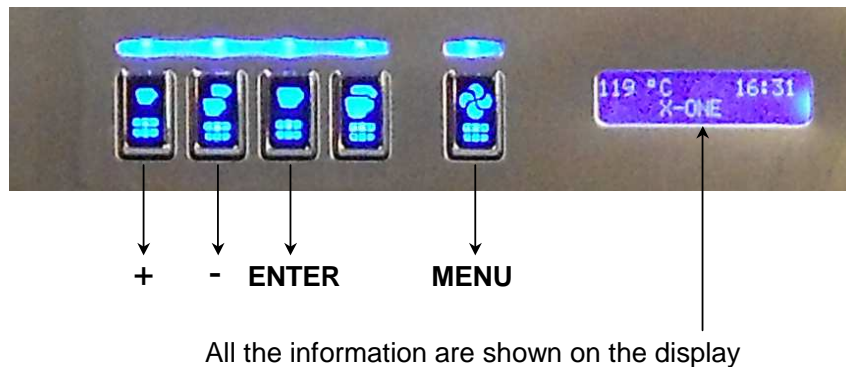

7.1 NORMAL MODE or ECO MODE:

- NORMAL MODE (machine ready to operate)

The machine turns on this mode, when the first heating is completed, and the setting temperature is reached. The display shows :

x°C	HH:mm
Name	

- ECO MODE (machine in stand by)

To be in **ECO** mode, keep pressing **MENU** button and press **ENTER**.
On ECO MODE the display shows:

x°C	HH:mm
ECO	

TO EXIT **ECO** MODE PRESS **ENTER** once time

7.2 TWO PROGRAMMING LEVEL:

There are 2 menus: **BAR** menu (Machine must be in Normal mode:)
TECHNICAL menu (Machine must be in Eco mode:)

7.3 COFFEE DOSES PROGRAMMING:

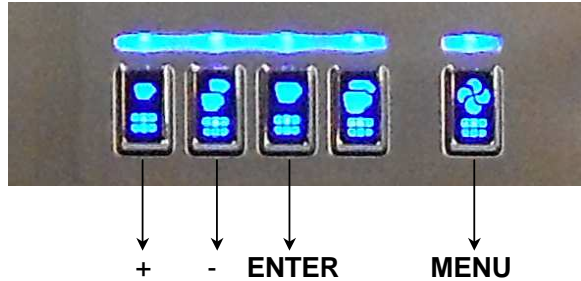

2 ways of programming are possible to set the coffee dose.

- Choose 1st group (on the left when the user is in front of the machine)
 - To program all groups at the same time with the same value.
 - The programmed key will have its equivalent key programmed identically on the others groups
- Choose each groups separately, if they the groups need to have different value against each other.

Methodology:

- ☞ Put the ground coffee (1 dose or 2 doses according to the programmed key), in the suitable filter holder.
- ☞ Press the key n°5 (MENU) from the selected group during 5 seconds.
- ☞ Display shows «*Press dose selection within 30s*».
- ☞ Press the key to be programmed to start the flow, and press again when water quantity is correct. The value is directly registered.
- ☞ Then, continue programming the next key within 30 seconds, and so on for the other keys.
- ☞ You can use any coffee button after the message « *Press dose selection within 30s* » disappears.

Note : On the factory, each machine undergoes a test protocol on which a program has already been completed, according to the following settings:

1 espresso = 2,5 cl / 2 espressos = 5 cl / 1 coffee = 4,5 cl / 2 coffee = 9 cl

7.4 HOT WATER DOSE PROGRAMMING:

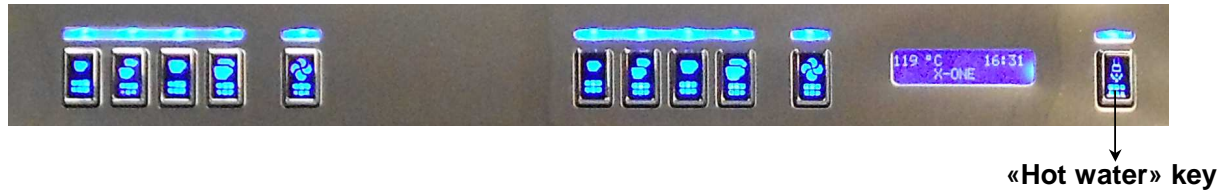

Methodology:

7.4.1 X-One

One programming dose is available:

- Press key n°5 (MENU) from the 1st group during 5 seconds.
- Display shows « *Press dose selection within 30s* ».
- Push **hot water key** to start the flow, and push again when the water volume is correct.
- You can use **hot water key** after the message «Press dose selection within 30s» disappears.

7.4.2 X-One TCI

Two programming doses are available, for 2 different volumes: 1x short and 1x long.

- Press key n°5 (MENU) from the 1st group during 5 seconds.
- Display shows « *Press dose selection within 30s* ».
- Push the **1st key “short hot water”** to start the flow, and push again when the water volume is correct (for exemple 1 cup of tea).
- Do the same operation, within a maximum of 30 sec, on the **2nd key “long hot water”** available.
- You can use **hot water key** after the message «Press dose selection within 30s» disappears.

7.5 AUTOMATIC CLEANING OF COFFEE GROUP :

The cleaning of coffee group is made group by group, preferably at the end of service, before the machine is stopped or put in "ECO" mode, using this specific function managed by the machine.

The procedure for cleaning coffee groups is as follows:

- ☞ Remove the filter-holder from the group and clean the seal with the supplied brush.
- ☞ Insert blind filter (provided with the machine) in the filter-holder.
- ☞ Put a detergent tablet (CONTI brand code: 466662) in the blind filter, and engage the filter-holder in the group.
- ☞ Keep pressing key n°5 (MENU), then press the key n°1 (1 espresso).
- ☞ The cleaning process starts automatically, with a 1st step of 10 "ON and OFF" cycles. (The display shows « cleaning in progress »). The purpose is to dissolve the tablet, and release the cleaning agent on the coffee group circuit and on the coffee valve.
 - ☞ Then this step stops for a 2nd step. (The display shows "Wait"). The machine waits for 1 minute in order to make the product acting.
- ☞ Release the filter-holder from the group and rinse it under water.
- ☞ Then, the 3rd step, is a rinsing during 20 seconds. (The display shows "rinsing").
- ☞ When the cleaning cycle is finished, the message disappears, and the group available again.
- ☞ Repeat this operating mode on each group, and each time the message « cleaning Grp i SVP » appears on the display.

The cleaning cycle can be interrupted, pushing any key of the concerned group. But, you will lost the following steps, and will compromise the cleaning efficiency.

It is possible to perform an automatic washing cycle for each group independently

7.6 ECONOMIC MODE :

The evening or before a long period of inactivity, the economic mode allows to keep the machine in standby

The display shows "ECO".

Then the boiler is maintained at a temperature of 60 ° C:

- which saves energy during the temperature drop
- and also during the standby period because the set-point temperature is low.

The output of "ECO" mode allows the machine to come back quickly to its operating parameters without spending lot of energy.

8 BAR MENU PROGRAMMING PARAMETERS:

The machine is in NORMAL mode, if not push once **ENTER** to exit Economy mode.

8.1 BAR MENU

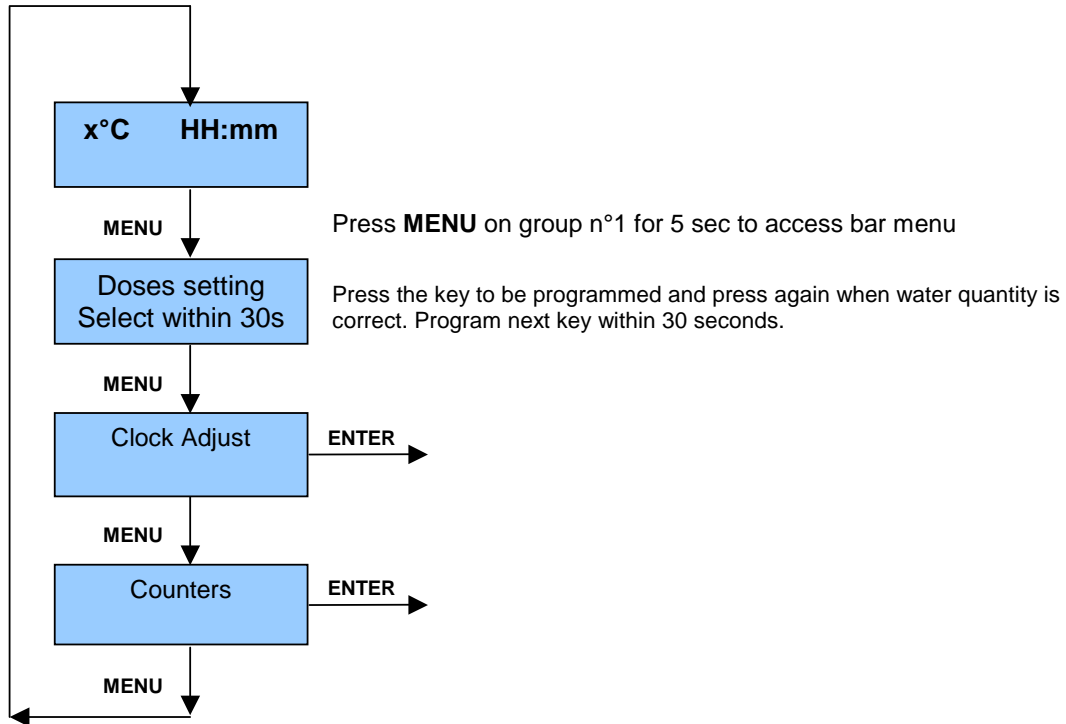

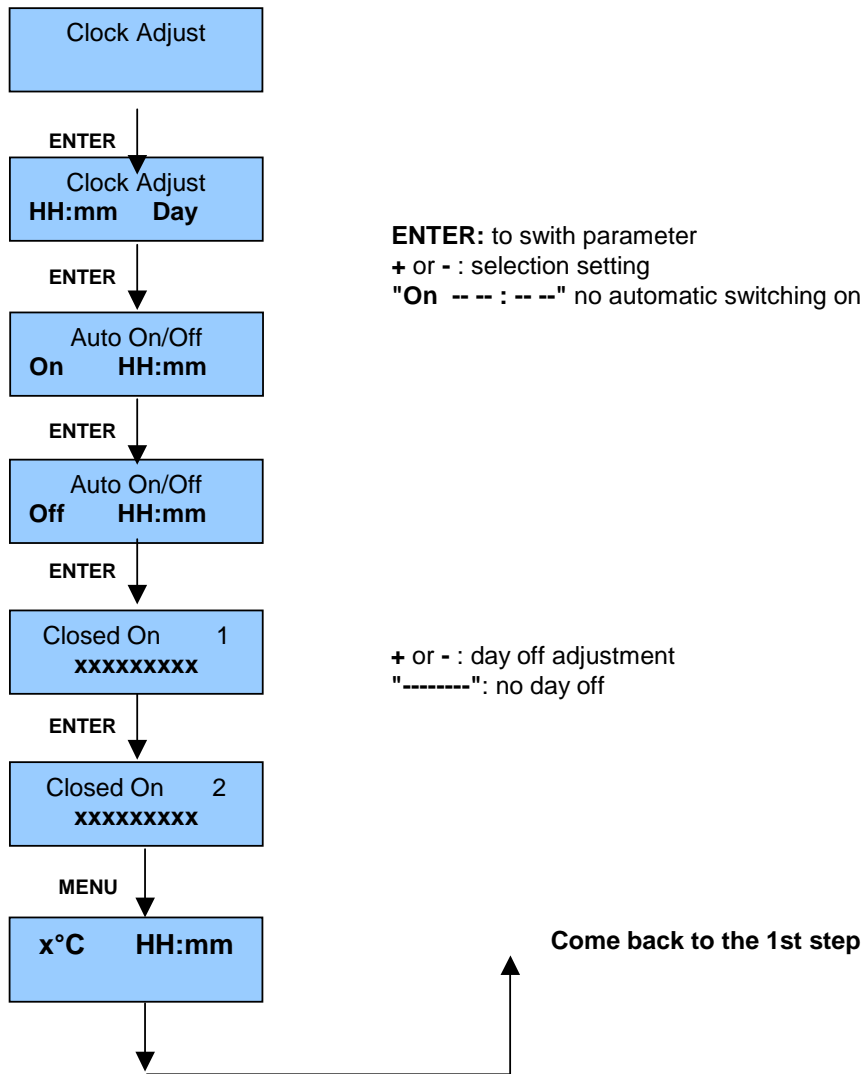

Counters

ENTER

Liters
0000

ENTER

Service
0000

ENTER

Espresso : Gr x
0000

ENTER

2 Espresso : Gr x
0000

ENTER

Coffee : Gr x
0000

ENTER

2 Coffees : Gr x
0000

ENTER

Continuous: Gr x
0000

ENTER

Tea:
0000

MENU

x°C HH:mm

ENTER: to swith parameter

+ or - : selection setting

"On --- : ---" no automatic switching on

Come back to the 1st step

8.2 PROGRAMMING EXPLANATIONS ON BAR LEVEL:

➤ Clock set:

Allows you to time the internal clock.

Press **ENTER** until clock set is displayed, then press + or – to adjust correct time.

HH: hour (0 ... 23)

mm: minutes (0 ... 59)

Day: week day

➤ Automatic on/off mode:

Allows to set the automatic switch ON and switch OFF time of the machine.

Press **ENTER** until automatic on/off mode is displayed, press + or – to set correct time.

On: HH:mm automatic switching on time

Off: HH:mm automatic switching off time

This Switching ON/OFF time is the same for all the days of the week.

To deactivate automatic on/off mode the display must show: **On:** -- -- . -- --

➤ Day off setting (Closed on)

Allows you to choose 2 days in the week, on which the machine won't start automatically.

You can choose 1 or 2 days off: the automatic switching mode will not switch the machine.

Select the days with + or – : Monday, Tuesday, Wednesday, Thursday, Friday, Saturday, Sunday.

To deactivate day off function the display must show: "-----"

➤ Counters:

Allows you to read partial coffee doses distributed.

Press **ENTER** to access to Counter menu

Press **MENU** to see each key. The display shows:

- Water quantity. (liters).
- Machine cycles number (service purpose).
- Espresso number (1 cup) on group 1, 2 and 3
- 2 espresso number (2 cups) on group 1, 2 and 3
- Coffee number (1 cup) on group 1, 2 and 3
- 2 coffees (2 cups) on group 1, 2 and 3

Note:

- The counter goes up to 65535 for each button. Then it restarts from 0.
- A distribution is recorded each time you push a button

➤ Counters reset:

☞ When the display shows:

Espresso Gr 1
xxx

☞ Press simultaneously buttons n°3 and n°4 on group n°1 for 3 seconds.

☞ The display shows then:

Espresso Gr:1
Reset Totals

☞ Then, all the counter for each button is reseted.

9 TECHNICAL MENU PROGRAMMING:

Machine must be in Eco mode. If not: keep pressed the **MENU** key, and press the **ENTER** key.

9.1 TECHNICAL MENU

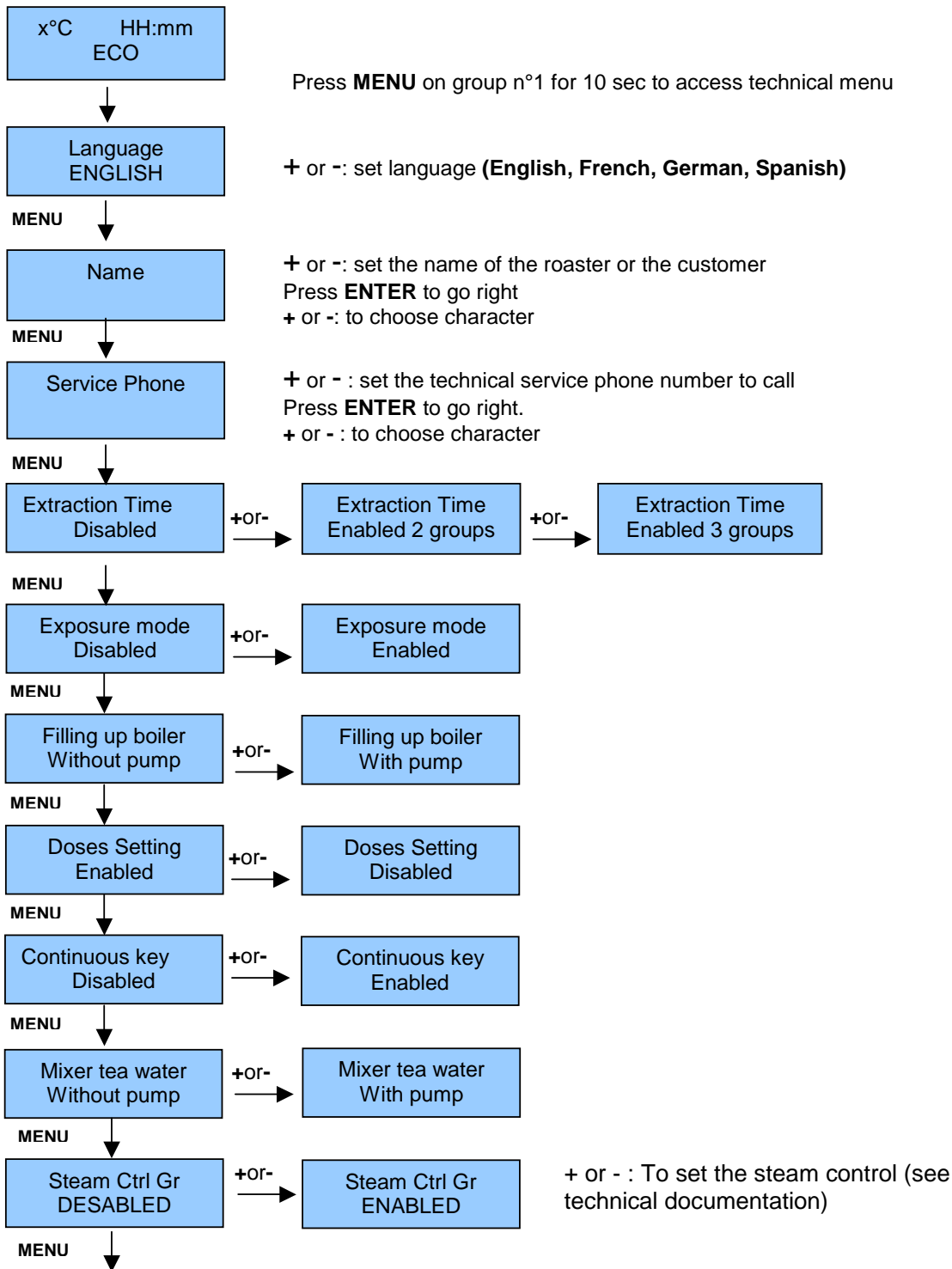

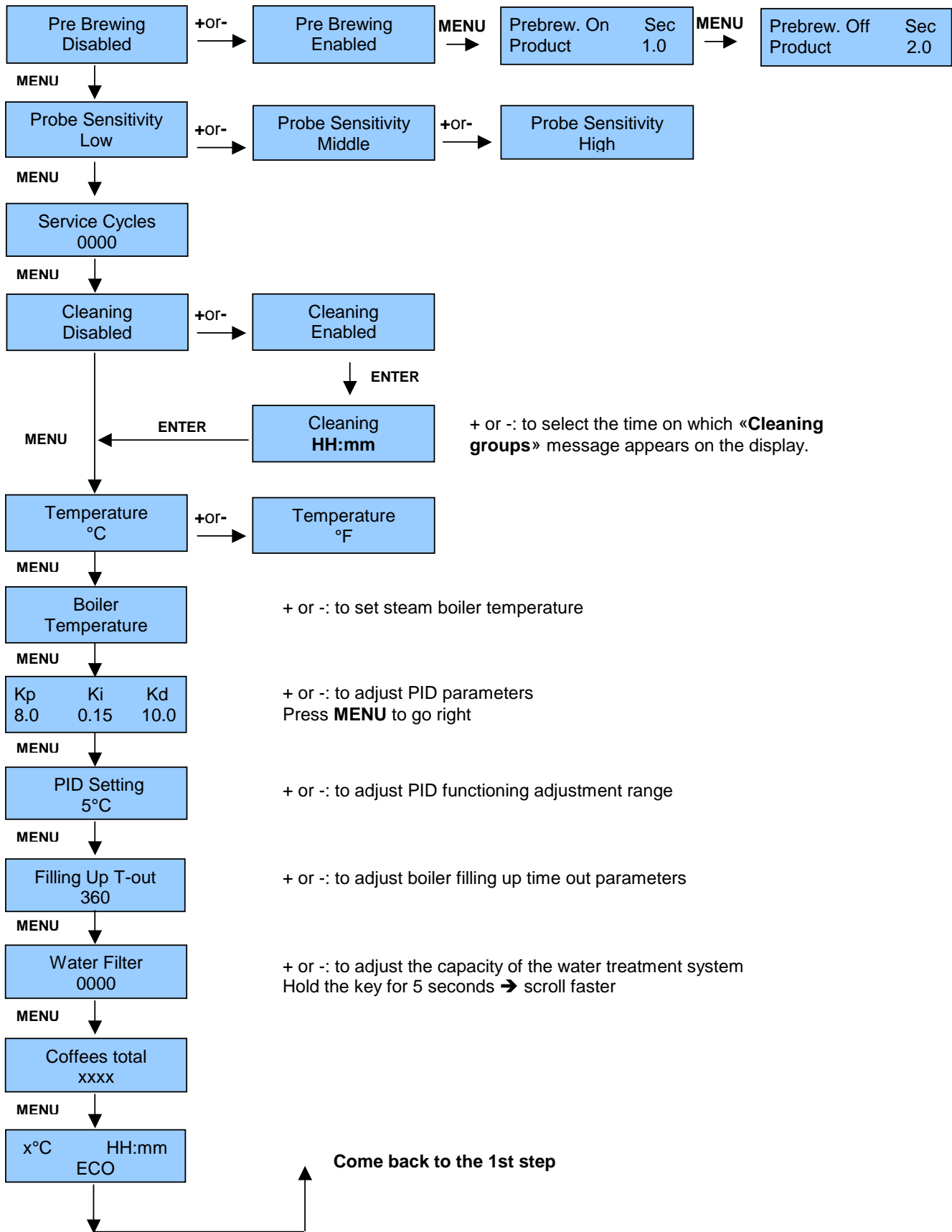

+ or -: to select the time on which «Cleaning groups» message appears on the display.

+ or -: to set steam boiler temperature

+ or -: to adjust PID parameters
Press **MENU** to go right

+ or -: to adjust PID functioning adjustment range

+ or -: to adjust boiler filling up time out parameters

+ or -: to adjust the capacity of the water treatment system
Hold the key for 5 seconds → scroll faster

Come back to the 1st step

9.2 TECHNICAL MENU PROGRAMMING EXPLANATIONS:

➤ Languages:

Set the language used for inscriptions on the display.

The available languages are: ENGLISH - FRENCH - ITALIAN - SPANISH

➤ Name:

Allows to sets the name that appears on the bottom line of the display:

The display shows:

x°C HH:mm Name

Cursor indicates the 1st character position:

- To change character press + or -
- Press **ENTER to go right**
- To finish press **MENU**

➤ Service telephone number:

Allows to sets the technical service phone number to call in case of failure.

This number appears on the bottom line of the display when a failure is detected by the electronics.
An alarm message appears at the same time.

Cursor indicates the 1st character position:

- To change character press + or -
- Press **ENTER to go right**
- To finish press **MENU**

➤ Extraction time on the display:

Allows you to see for each group, the extraction time done to make a coffee.

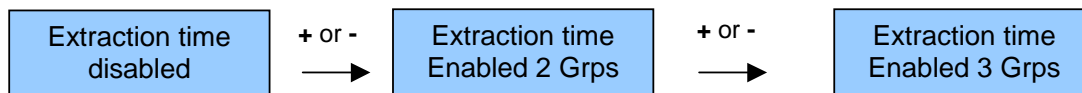

To see this «Extraction time» on display, you need to activate this function. This setting is done by pressing + or - . Button. You need to choose for a 2 groups or a 3 groups machine

When «Extraction time» is activated, display shows:

For a 3 groups

T1 XX s	T2 XX s	T3 XX s
-------------------	-------------------	-------------------

For a 2 groups

T1 XX s	T2 XX s
-------------------	-------------------

Time starts to run from the start of the infusion (pre infusion is not recognized) and ends at the closing of the solenoid coffee. Time (max 99 sec) is displayed until another coffee is done.

T1 is the extraction time recorded on group 1.

T2 is the extraction time recorded on group 2.

T3 is the extraction time recorded on group 3.

➤ **Exposition mode :**

If the exposition mode is « active », The machine is completely ON, but don't react to any button, and don't control any heating. This status is shown by the word « EXPO » written on the display.

To come back to the normal mode:

- Enter in the technical menu programming
- Desactivate the exposition mode

➤ **Filling the boiler:**

Allows to choose the filling mode of the steam boiler

- With pump (if the machine works with tank)
- Without pump (if the machine is connected on the network)

➤ **Dose programming access:**

Allows you to leave or prevent access of the program doses.
The setting change is made with the + or -.keys.

➤ **Continual dose access:**

Allows you to leave or prevent access of the continuous key.
The setting change is made with the + or -.keys.

➤ **Hot water distribution mode:**

Allows you to choose if the hot water is distributed:

- Only by opening the valve.
- Or by activating the pump and the hot water valve.

This is the case when using a mixer

➤ **Steam control :**

Setting parameters for the emulsion of 1 liter of milk foam on the X-TCI steam control.

Steam boiler T° 124 or 125 ° c

Steam control target T° 70 ° C

Milk qty in jug. 0.6 L

Standard air nozzle. yes

➤ **Pre Brewing setting:**

Allows you to leave or prevent the use of the pre-brewing on each button. (to be define).

The setting (disable or enable) is made with the + or -.keys

You can set the pre-brewing time on the 4 different doses (those 4 setting will be the same on each group) by pressing **MENU**. The displays will show:

Prebrew On	Sec
Product	1.0

Preinfusion time is in seconds.

First adjust all times **On**, then all times **Off** .

Product name = espresso – 2 espresso – coffee – 2 coffees.

To move forward press **MENU**

To exit, wait 30 seconds and do not press any button.

➤ **Level probe sensitivity:**

According to the water hardness in the tanker, this allows you to adjust the sensitivity of the level probe.

The setting is made with **+** and **-** key.

Setting values: **LOW, MIDDLE, HIGH**

- **LOW:** softened water hurt
- **MIDDLE:** normal water
- **HIGH:** mountain water, or very pure water

➤ **Service cycles:**

Allows to set the number of cycles (or coffee) that the machine can perform before a preventive maintenance is required.

The setting is made with **+** and **-** key, with steps of 1000 cycles

Values are adjustable from 0000 (not management) to 99000

To reset, see chapter "Troubleshooting and Remedies - services»

➤ **Compulsory groups cleaning programming:**

Allows you to program a requirement for a compulsory cleaning **at a specific time**.

If the group cleaning programmed is not done on all groups: **machine is blocked**.

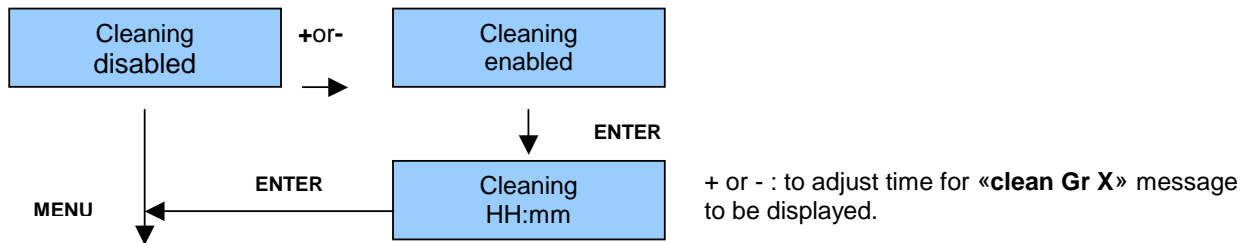

The activation of **compulsory cleaning** function is made with **+** or **-** keys.

To set the time for the message « Groups cleaning » to be displayed press «**Enter**» and then press **+** or **-**.

➤ **Temperature unit choice:**

Allows you to define the unit temperature **°C** or **°F**

All values are automatically converted when you change the unit.

➤ **Steam boiler temperature adjustment**

Allows you to define the setting temperature in the steam boiler.

Adjustment range: 80 to 125 °C (176 °F ... 257°F)

Resolution: 1°C

We advise **120°C** for X-ONE,
123°C for X-ONE TCI.

To change temperature press **+** or **-** key.

To exit, press **MENU**, or wait 30 seconds.

➤ **PID adjustment range**

The PID is a system for adapting the heating power in the coffee boiler.
The goal is to have a better stability of the T ° in the coffee boiler

Principle of operation:

Every 2 seconds, electronics evaluates the power to provide to the heater. This calculation is performed in a working range of 5 ° C around the setting temperature (range = 5 ° C). Beyond that, the machine is full power.

This calculated power is depending on the measured temperature weighted by 3 coefficients:

- Where is the temperature: Kp
- At what speed is changing the temperature: Kd
- How has evolved the temperature since the beginning: Ki

This gives a percentage rise of full power given to the heater. And It' shown by the blinking leds on the solid state relays.

It is recommended to keep the default settings.

- PID system is a compromise between SPEED and PRECISION.
- The aim is to limit overruns while maintaining accuracy, speed and robustness.

➤ **Filling up Time out adjustment:**

It allows to allocate to the machine a maximum permissible time for filling the boiler.
Beyond this time, machine stops and an alarm message is displayed.

The values are in seconds.

The setting is made with + and – **key**.

To exit, press **MENU**, or wait 30 seconds.

➤ **Water softener:**

This menu concern the water treatment parameters. We define the alarm threshold before changing the filter (0 to 9999 litres).

The amount of water consumed includes:

- The water passes through the coffee flowmeters.
- The water enters the steam boiler

The setting is made with + and – **key**. (Hold the key for 5 seconds → scroll faster)

To exit, press **MENU**, or wait 30 seconds.

When the water volume consumed is reached, the display shows:

Change filter

To reset the counter, when the filter has been changed: see chapter “reset counters”

➤ **Total coffee:**

This Indicate the total number of products (coffee + tea) produced since the installation of the machine.
This counter is not resettable.

10 ALARM MESSAGES AND SOLUTIONS:

➤ Cleaning alarm:

When the message "**compulsory cleaning**" appears on the display, the user need to start an automatic cleaning on each groups (one after the other).

If it does only partially (1 group instead of 2, for example) or if it does not, the machine will no longer be used and the message "Warning cleaning groups" remain permanently displayed on the display.

This message will disappear when all groups have been cleaned.

The machine comes back to NORMAL MODE.

➤ Cleanning Gr : X SVP

After 250 coffees on one group, the display shows «**Please Cleaning Gr: X**»

The machine is usable, but the message will not disappear until the cleaning has not been made. To remove the alarm, simply run an automatic cleaning (see chapter: use)

Nota: Automatic cleaning is always possible even if there is no message on the display.

➤ Filling up time out:

The high level probe SN did not detect water within the programmed time (250 sec).

Possible reasons: Water inlet solenoid valve must be cleaned.
 Water inlet solenoid valve does not work.
 Water high level probe is disconnected.
 Water inlet tap is closed.

Solution: After checking up, cut the mains then put it back.

➤ Boiler temperature alarm message

The electronics detected a temperature > 140 °C for more than 5 seconds in the boiler.

Alarm message disappears when temperature decreases 2°C under the limit.

➤ Temperature probe open

The electronics does not detect the temperature probe.

Possible reasons: Reconnect or replace the temperature probe.
 Check temperature probe cable, replace if necessary
 Mother board may be damaged
 Check the connector on the mother board

➤ Flowmeter alarm Gr X

The electronics does not receive group X flowmeter information.

Possible reasons: No water in the flowmeter
 Damaged cables
 Damaged flowmeter
 Coffee too fine
 The water inlet tap is closed.

➤ Water softener maintance alarm:

When programmed water quantity is reached, display shows «**change filter**» together with the programmed telephone number (machine keeps on working).

After servicing the water filter, please do the following:

- Switch off the machine (ON / OFF button).
- Press continuously buttons n°3 and n°4 on the left group while
- Switch on the machine (ON / OFF button)
- Display shows «**Filter Reset**».

Counter restarts from 0.

➤ **Service:**

When service cycles number is reached, display shows «Service» together with the programmed telephone number for service (change check valve gaskets, limiter, steam tap gaskets...).

After servicing the machine, please do the following:

- Switch off the machine (ON / OFF button).
- Press continuously buttons n°1 and n°2 on the left group while
- Switch on the machine (ON / OFF button)
- Display shows «**Service Reset**».

Counter restarts from 0.

➤ **The machine does not turn on:**

The klaxon is open and/or general relay is not supplied.

Possible reasons: The heating boiler operate without water
 General relay coil is switched off.

Solution: Disconnect the machine from the power
 Reset manually the klaxon
 Check for water in the boiler
 Restart the machine.

11 SUMMARY OF PROCEDURE FOR RESETTING THE COUNTERS

11.1 RESETTING THE COFFEE COUNTER

- Go on the programming parameters on the BAR level.
- In the Counter step menu
- Press « ENTER »

- When the display shows:

**Espresso Gr: 1
XXX**

- Press simultaneously the key n° 3 and n°4 from the group n°1 during 3 seconds,
- The display will show:

**Espresso Gr: 1
Total Reset**

Note : The total coffee counter can't be reseted.

11.2 RESETTING THE "MAINTENANCE" COUNTER

When the maintenance has been done, the calling message need to be deleted. The procedure is as follow :

- Switch off the machine with the ON/OFF button (below the machine).
- Keep the key n°1 et n°2 from the left group pressed.
- Swtich on the machine with the ON/OFF button
- The display shows : « Service Reset »

The counter "maintenance" is reseted.

11.3 RESETTING THE « FILTER » COUNTER

When water treatments have been regenerated, or filters have been changed,, the calling message need to be deleted. The procedure is as follow :

- Switch off the machine with the ON/OFF button (below the machine).
- Keep the key n°3 et n°4 from the left group pressed.
- Swtich on the machine with the ON/OFF button
- The display shows : « Filter Reset »

The counter « filter » is reseted.

12 TROUBLESHOOTING FACILITATORS

12.1 STOPPING TAPS :

Somes stopping taps, located below the drip tray, allows the technician to isolate coffee circuits of each group.



It can be usefull to remove a defective part (flowmeter as exemple), and keep the machine operating on the other groups.

12.2 DATA RESET:

It is possible to restart the machine, machine will then have the standard settings.

Procedure:

- _ Cut the mains.
- _ Press continuously buttons n° 1, n° 3 and n° 5 on group 1 while
- _ Put back the mains.
- _ If display shows «**preset valori completato**», **RESET** is done.

To go back to normal use, cut and put back the mains.

12.3 COLD CONDITIONS FUNCTIONNING:

UNDER CONSTRUCTION

13 METHOD OF ADJUSTING COFFEE TEMPERATURE ON X-ONE MODEL

- X-one machine are adjusted in the factory, with a boiler temperature of 120°C (1MPa).
- The break is adjusted for a coffee temperature under spout of 87°C/89°C.
- Measured according to a standardized protocol of the manufacturer, this value is given as a reference.
It can change according the following parameters:
 - Extreme ambient conditions (15 ° C - 35C)
 - An extraction time shorter or longer than the standard.
 - The volume of water in the cups

13.1 AJUSTEMENT DE LA TEMPERATURE CAFE :

- ⇒ Perform a series of 6 consecutive double coffees.
- ⇒ On the last coffee: measure the coffee temperature under spout.
- ⇒ Correct, if necessary, this value acting on the steam boiler temperature

Indication: 2°C steam boiler ⇔ 1°C coffee temperature under spout.

13.2 THERMOSIPHONIC BALANCE :

- When the coffee temperature under spout is established « in continuous », wait for 1/4 hour (thermosiphonic stabilization)
- Check the coffee temperature under spout on a 1st coffee.
 - ⇒ Correct, if necessary, this value with the break:

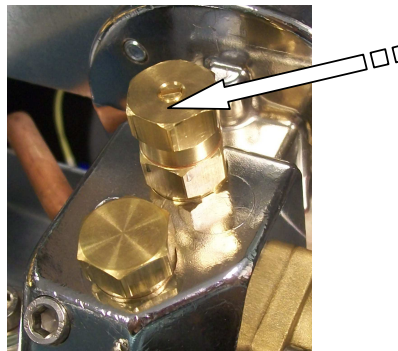

Procedure: Turn the screw  clockwise to decrease (↘) the coffee T°.

Turn the screw  anti-clockwise to increase (↗) the coffee T°.

Indication: ½ of a turn of break ⇔ 2°C on coffee T° under spout.

14 METHOD OF ADJUSTING COFFEE TEMPERATURE ON X-ONE TCI MODELS

- X-one tci machines are adjusted in the factory, with a boiler temperature of 124°C (1,3MPa).
- The break and the mixer are adjusted for a coffee temperature under spout of 85 °C.
- Measured according to a standardized protocol of the manufacturer, this value is given as a reference.
It can change according the following parameters:
 - Extreme ambient conditions (15 ° C - 35C)
 - An extraction time shorter or longer than the standard.
 - The volume of water in the cups

14.1 STEAM BOILER TEMPERATURE ADJUSTMENT:

According to the needs of steam, adjust the setting temperature of the steam boiler. This value can be set from 116°C (0,74MPa) to 124°C (1,4MPa).

Indication: The coffee temperature under spout will change according this adjustment :
2°C on steam boiler ⇔ 1°C coffee T° under spout.

14.2 COFFEE TEMPERATURE ADJUSTMENT:

- ⇒ Perform a series of 6 consecutive double coffees.
- ⇒ On the last coffee: measure the coffee temperature under spout.
- ⇒ Correct, if necessary, this value acting on the mixer



Proczdure : Turn the wheel  clockwise to increase (↗) the coffee T°.

Turn the wheel  anti-clockwise to decrease (↘) the coffee T°.

Indication: 1/4 of a turn mixer ⇔ 2°C on coffee T° under spout.

14.3 THERMOSIPHONIC BALANCE :

- When the coffee temperature under spout is established « in continuous », wait for 1/4 hour (thermosiphonic stabilization)
- Check the coffee temperature under spout on a 1st coffee.
 - ⇒ Correct, if necessary, this value with the break:

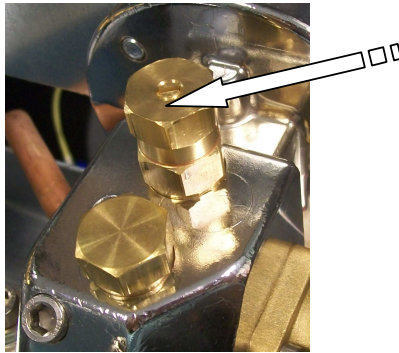

Procedure:

Turn the screw  clockwise to decrease (↘) the coffee T°.

Turn the screw  anti-clockwise to increase (↗) the coffee T°.

Indication: ½ of a turn of break ⇔ 2°C on coffee T° under spout.

15 HOW TO MAKE THE PERFECT COFFEE

Obtaining a good cup of coffee is the result of certain conditions: the 5 golden rules of perfect espresso:
MIX / GRINDER / MACHINE / HAND / and MAINTENANCE.

➤ The Mix:

- The type of coffee is very important. It can be distinguished 2 mains qualities:

- ARABICA:

It gives a fragrant taste, sweet, chocolaty, slightly acid, with a pleasant bitterness. The coffee color is hazelnut cream

- ROBUSTA:

It gives a less fragrant taste, rough, astringent and significantly more bitter. The caffeine content is about twice. The coffee color is greyish brown.

- The roaster has a great importance on the quality of each coffee (choice of grain, selection processes, roasting, packaging processes, ...).

➤ The Grinder:

The grinder and the grind adjustment are essential:

- The coffee grinder:
grinding capacity of the coffee beans must be commensurate with the needs of the user. Indeed, excessive use causes overheating of the mill wheels and thus a rapid realignment of the mill.
- The grind adjustment:
setting the mill to choose the fineness of the grind and the right dose required to achieve optimum coffee. The dose should be adjusted to 7 grams for a cup; finesse should allow a flow time of coffee in the cup about 20 - 25 seconds: this time ensures the dissemination of flavors in the cup.

➤ The Machine:

It must be well adjusted and kept very clean !

- Pump Pressure limited to 9 MPa.
- Water temperature out of the shower must be between 86 °C and 92 ° C
- Correct programming doses.
- Daily cleaning performed every evening.
- Ensure that the water treatment is operating well.
- Follow the maintenance recommendations

➤ **The Hand:**

Skill of the operator: He must of course control the above three factors, but also:

- He know how to maintain coffee.
 - For exemple, a milling do not remain in the open air.
 - He know that coffee bean loses 1% of its flavor by day ground coffee, it loses 45% day.
 - Therefore he avoid grinding too much coffee at once, or keep in drawers.
- The filter-holder need to be warm, so it must be maintained on the group.
- The cups need to be warm, about 40 ° C. They are therefore placed on the cup warmer.
- He damp correctly the coffee in the filter-holder.
- He ensure proper regularity milling for constant quality coffees.

➤ **The Maintenance**

This is the necessary condition for the success of a good coffee:

At the end of each daily period of activity, it is strongly recommended to perform a cleaning operation on each group coffee.

Double impact:

- Improve coffee quality by eliminating oxidized fats
- Ensure the proper operation of the coffee group.

16 MAINTENANCE OF MACHINES

➤ DAILY MAINTENANCE

- Clean the hot water outlet and the steam outlets with a scouring pad:
 - o Use a needle to keep the diffuser outlets unclogged.
 - o Then purge by opening the tap a few seconds.
- Clean the drip tray and the basin, removing them from the machine.
- Remove the filter-holder from the groups and clean the seal injection filter-holder with the brush.
- Use the automatic process cleaning:
 - o Insert blind filter in the filter holder and place the CONTI cleaning tablet code n°466662
 - o Engage this filter-holder on the group to be cleaned
 - o Simultaneously press the 5th (continuous) and the first key (1 espresso)
 - o The automatic cleaning process of the group is started in 3 steps:
 - o The process is shown on the display.
 - o Follow the instructions on the display.
 - o Repeat this procedure on each group.
- Brush the filters in water containing detergent:
 - o In order to unclog the holes
 - o Never use a needle or a flame.

➤ HALF YEAR MAINTENANCE:

- A kit n° 480330, for the following operation is available for sale.
- For each group:
 - o Remove the sprinkler, diffuser, and seal gasket.
 - o Scrub the gasket groove and the supplying hole on the group head.
 - o Clean the two parts of the diffuser. Clear all the holes with a needle.
 - o Reassemble the 2 parts of the diffuser on the group head
 - o Place NEW Filter gasket, and NEW sprinkler.
- Remove and clean the level sensor (limestone deposit).

➤ **ANNUAL MAINTENANCE:**

- A kit n° 480331, for the following operation is available for sale.
- Change the pump inlet filter (No. 411861)
- On the boiler:
 - o Change vacuum valve (No. 408898)
 - o Change the safety valve (No. 404326)
- On the inlet bloc valves:
 - o Change the filter (No. 470199)
 - o Replace the gasket (No. 219100) of 2 non-return valves
 - o Remove and clean the gasket limiter 12 Bars
 - o Clean the nucleus of the solenoid inlet water boiler
 - o Clean the nucleus of the small solenoid "mixer"
- On the coffee group
 - o Change the O-ring nozzle (No. 403457) and the filter nozzle (No. 403458)
 - o Change the 2 O-rings (No. 403457) of the breaker
 - o Change the O-ring (No. 067100) on the breaker
 - o Clean the 3rd way and the nucleus of the solenoid coffee valve
- On the electrical tap
 - o Clean the nucleus of the solenoid "hot water" valve
- On the 2 steam taps:
 - o Change the 2 O-rings (No. 403457)
 - o Change the 1 gasket (No. 407502)
- On the 2 "steam" output and on the "hot water" output
 - o Change the O-ring (No. 061200)
 - o Change the O-ring (No. 055300)
- For water quality issues, it is recommended to fully drain the boiler.

➤ **ENTRETIEN BIENNAL:**

- A kit n° 480331, for the following operation is available for sale.
- Change the pump inlet filter (No. 411861)
- On the boiler:
 - o Change vacuum valve (No. 408898)
 - o Change the safety valve (No. 404326)
- On the inlet bloc valves:
 - o Change the filter (No. 470199)
 - o Replace the gasket (No. 219100) of 2 non-return valves
 - o Remove and clean the gasket limiter 12 Bars
 - o Change the inlet boiler valve (No. 470161) + 2 PTFE gasket (No. 407500)
 - o Change the small solenoid "mixer" (No. 411374)
- On the coffee group
 - o **Remove all the parts and uncork all the holes in the group head.**
 - o Change the O-ring nozzle (No. 403457) and the filter nozzle (No. 403458)
 - o Change the 2 O-rings (No. 403457) of the breaker
 - o Change the O-ring (No. 067100) on the breaker
 - o Change the solenoid coffee (No. 407329) + 2 PTFE gasket (No. 407500)
- On the electrical tap
 - o Change the solenoid "hot water" (No. 470161)
 - o Change the 2 PTFE gasket (No. 407500)
 - o Change the O-ring of the adjusting screw (No. 400 039)
- On the 2 steam taps:
 - o Change the 2 O-rings (No. 403457)
 - o Change the 1 gasket (No. 407502)
- On the 2 "steam" output and on the "hot water" output
 - o Change the O-ring (No. 061200)
 - o Change the O-ring (No. 055300)
 - o Change the washer (No. 401320)
 - o Change the O-ring of steam nozzles (No. 055400)
- For versions TCI: in the mixer:
 - o Change the O-ring (No. 087520)
- Change the silicone tubes evacuation 3-way valves cafes (No. 405621)

17 ELECTRONIC DIAGRAM STANDARD VERSION

17.1 DESIGNATION OF USEFUL CODES

REF.	DESIGNATIONS
ON/ OFF	ON / OFF BUTTON
CE	ELECTRONIC CARD (MOTHER BOARD)
CV X	FLOWMETER
SONDE 1	TEMPERATURE PROBE FOR STEAM BOILER
SONDE 2	TEMPERATURE PROBE FOR STEAM CONTROL SYST
CN1 / CN2 / CN3	CONNEXION FOR CONTROL COFFEE BUTTONS GR X
EV EE	FILLING UP SOLENOID VALVE
EV GR X	COFFEE GROUP X SOLENOID VALVE
EV LV	STEAM CONTROL SYSTEM SOLENOID VALVE
MP	COMPLETE PUMP
EV THE	TEA SOLENOID VALVE (HOT WATER)
RC	HEATING ELEMENTS
RS X	STATES RELAYS 1/ 2 /3
SN	LEVEL SENSOR
KLIXON	KLIXON
BP	BUTTON ON/OFF
EV AIR	AIR SOLENOID VALVE
EV LAV	LAV SOLENOID VALVE

CODE COULEURS FILS CABLE COLOUR CODE

1	marron	brown
2	rouge	red
3	orange	orange
4	jaune	yellow
5	vert	green
6	bleu	blue
7	violet	violet
8	gris	grey
9	blanc	white
0	noir	black

17.2 ELECTRICAL HEATING CIRCUIT FOR X-ONE 2G 230V 3500W

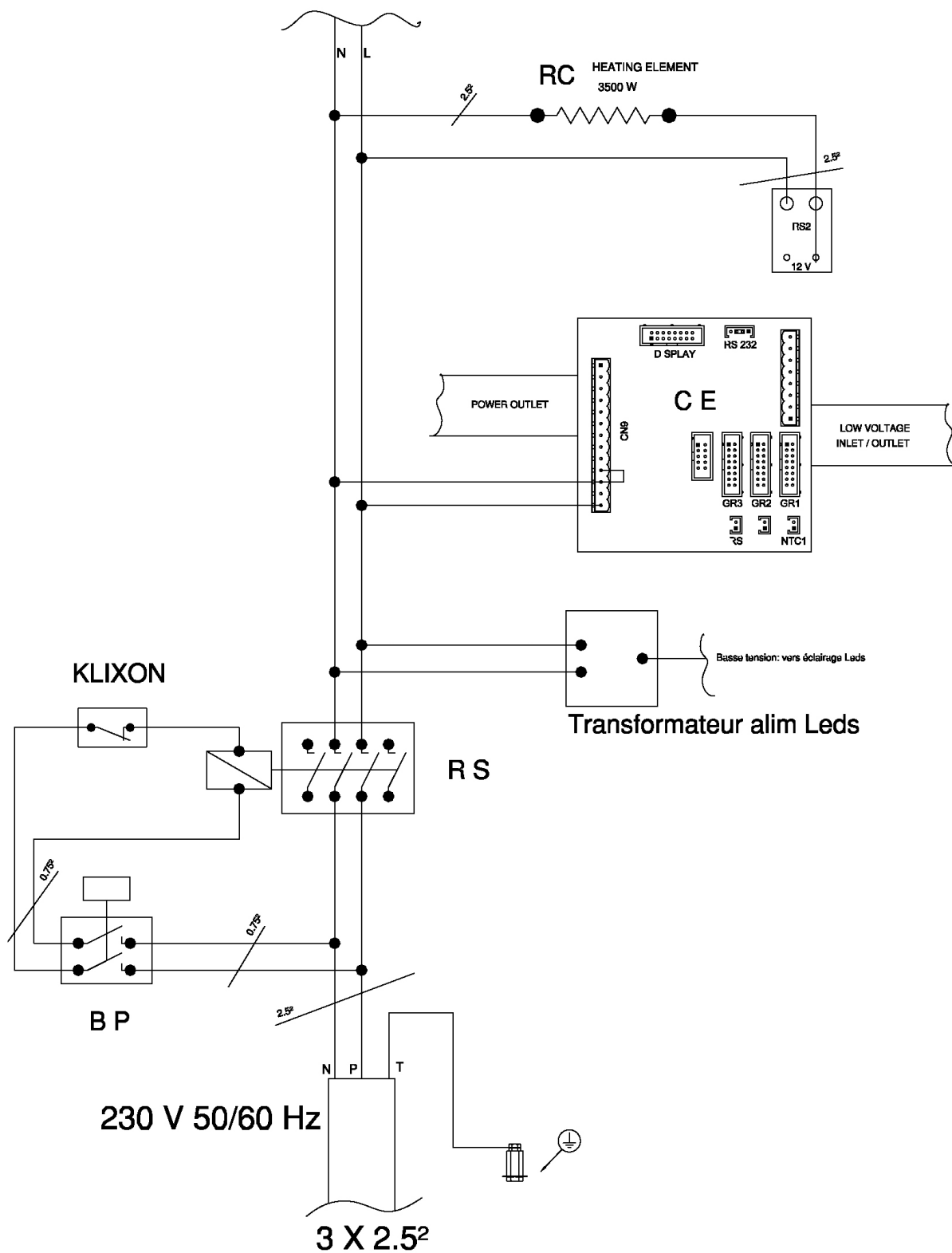

17.3 ELECTRICAL HEATING CIRCUIT FOR X-ONE 3G 230V 6000W

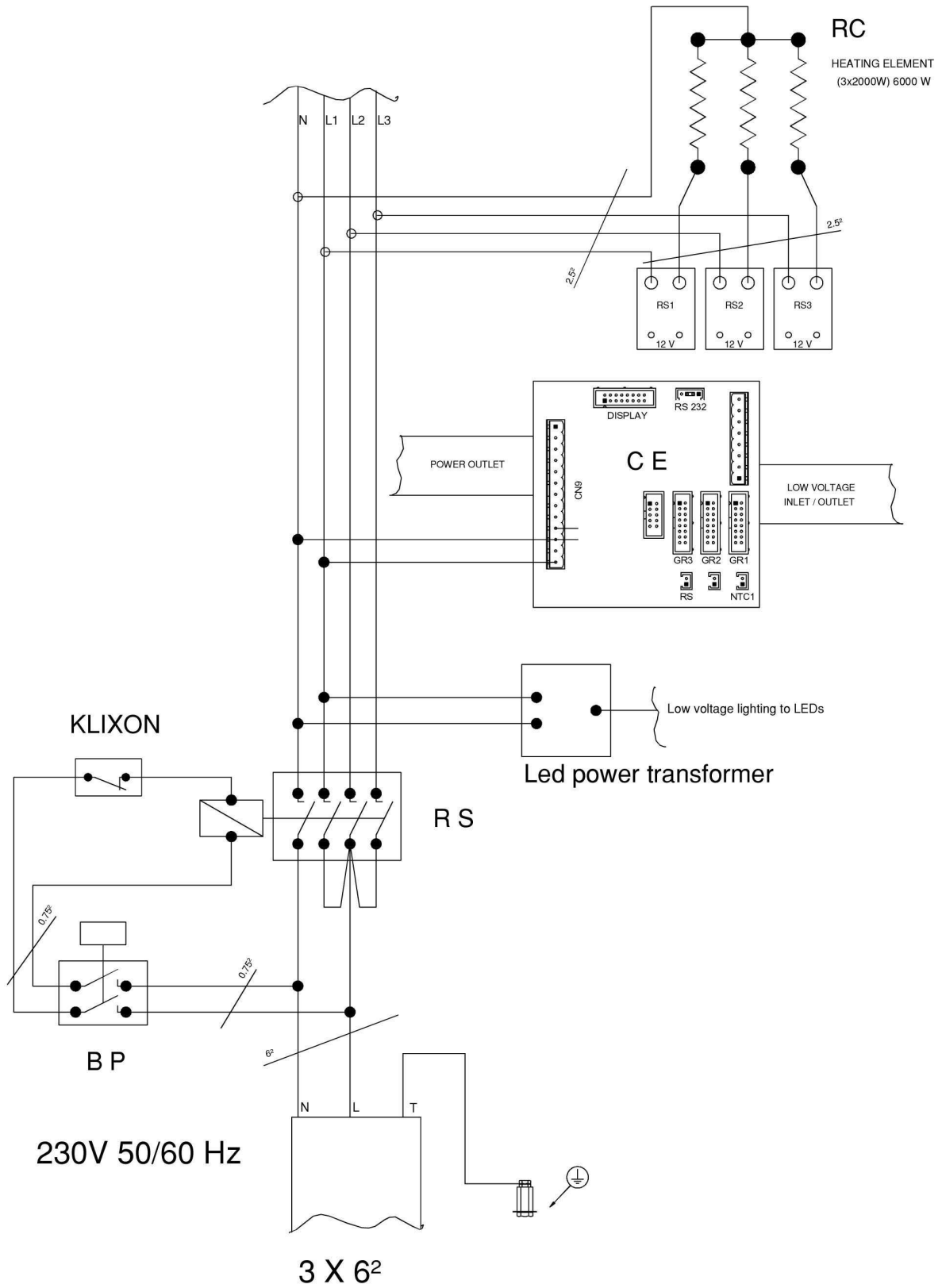

17.4 ELECTRICAL HEATING CIRCUIT FOR X-ONE 3G 400V 6000W

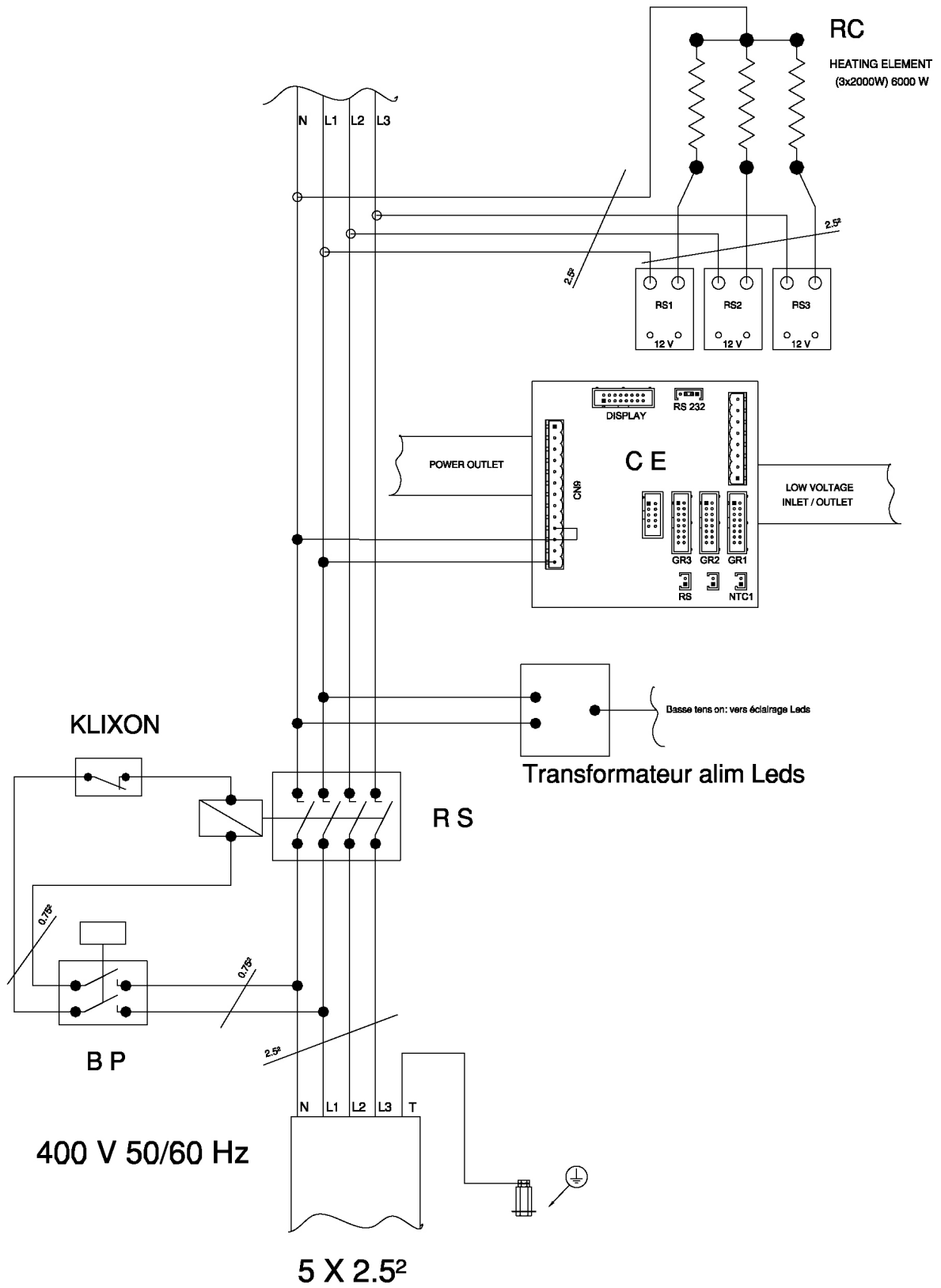

17.5 ELECTRICAL HEATING CIRCUIT FOR X-ONE 2/3G 230V 3L PE 6000W

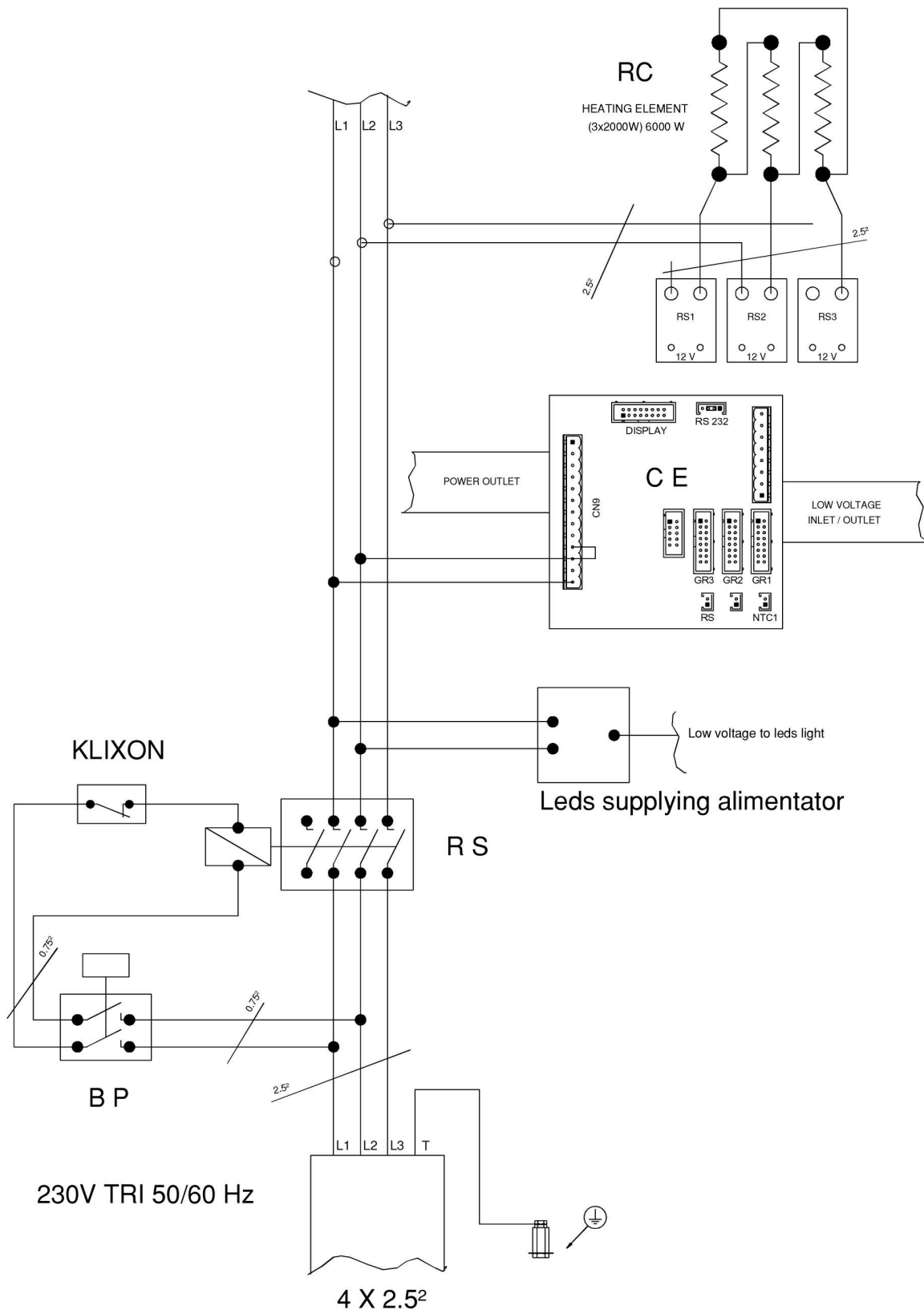

17.6 ELECTRICAL POWER CIRCUIT FOR X-ONE (STEAM CONTROL VERSION)

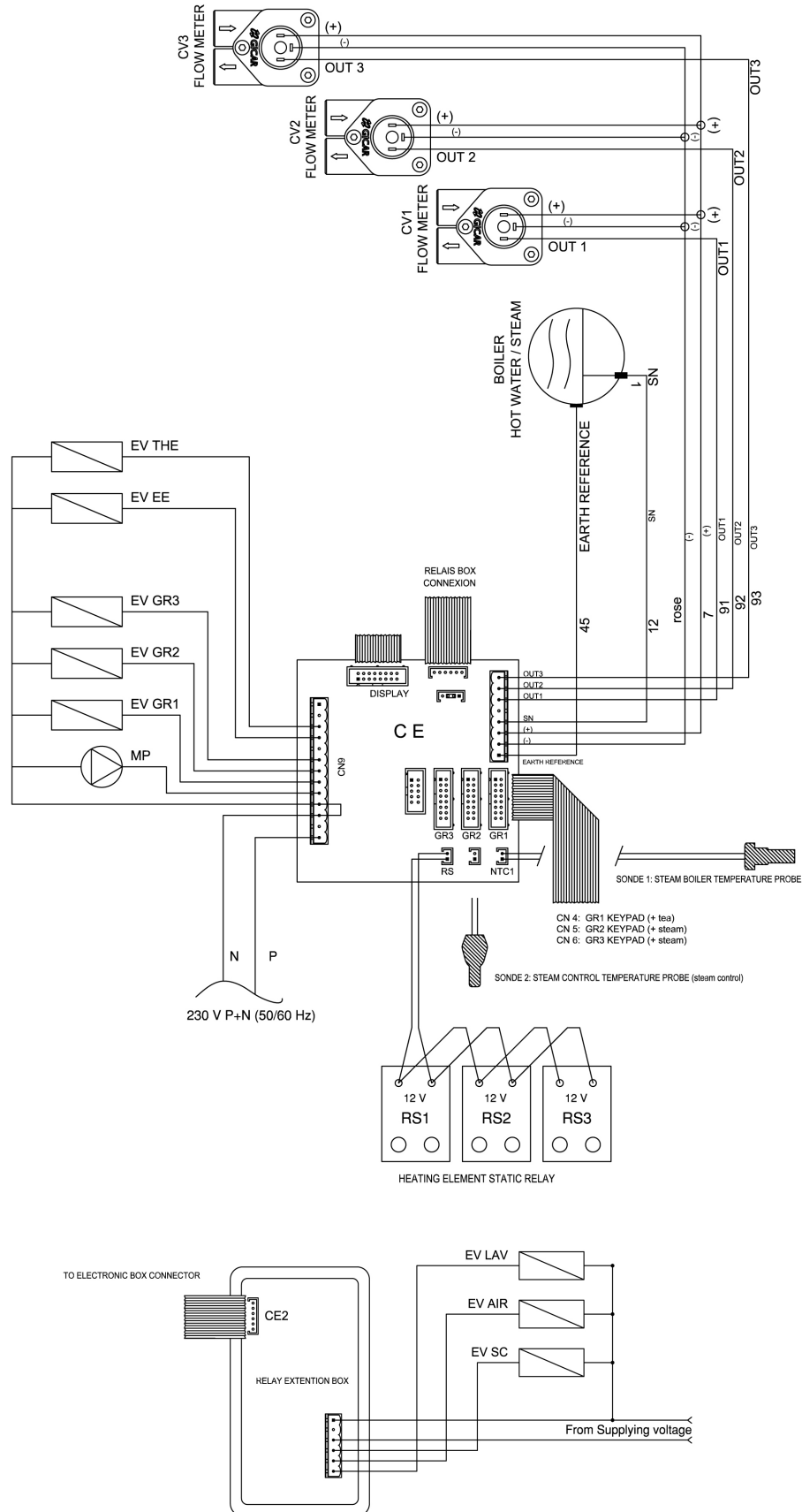

18 HYDRAULIC SCHEMA

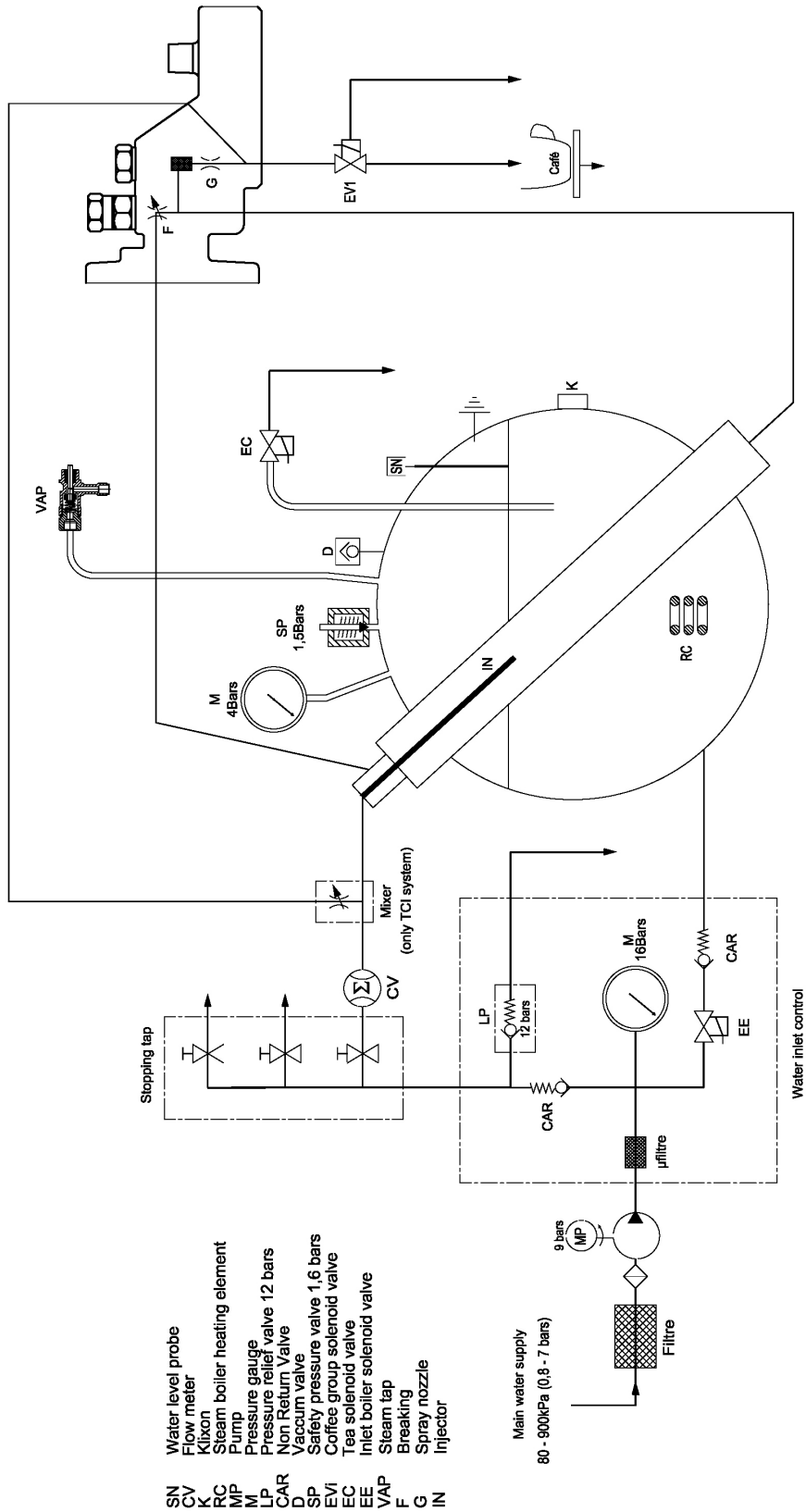

19 OPTION AVAILABLE

19.1 SOLO KIT

In case of insufficient pressure on the water system, or if the water supply is non-existent, you must use separate water tanks.

The machine must operate in SOLO mode:

- In the technical menu must be set filling "PUMP"
- The machine draws its water from the reservoir provided.

We propose for that a solo kit No. 411618 (order separately)

This kit consists of the following elements:

- 1 corrugated input to connect at the inlet of the machine
- 1 hose to connect to the corrugated input
- 1 "strainer + non return valve" to connect to the other side of the hose.

The role of the strainer is to ensure that the pump remains primed again.

CONTI

— E S P R E S S O M A C H I N E —



web

La Ruche - 1, Avenue Albert II - B.P.119 - MC 98007 MONACO Cedex
Tél.: (377) 93 10 43 43 Fax : (377) 93 10 43 44
[http ://www.conti-espresso.com](http://www.conti-espresso.com) [http ://www.conti-spareparts.com](http://www.conti-spareparts.com)
E-mail:tech@conti-espresso.com